

ZM-18-green

Industry / Craft

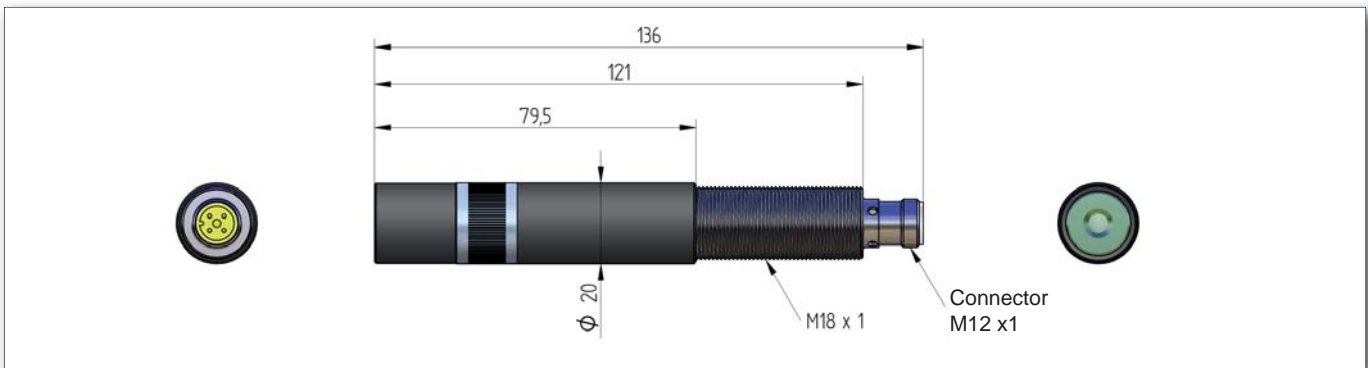

Brand new product for a variety of applications



Features

- 5-30VDC operation with reverse polarity protection
- Highly visible green light with a 4mW output
- IP67 rated, fully waterproof
- Simple, external hand focusing mechanism
- Thread mounted for simple and versatile mounting
- LED laser operation indicator
- Gaussian, uniform and DOE optics available
- M12 connector guarantees an ideal electrical connection
- Electrically isolated housing

Applications

- Positioning
- Wood processing
- Metal processing
- Textile industry
- Stone processing
- Food industry
- Medical science
- Automotive industry

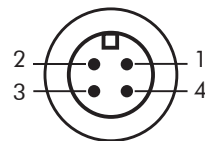

1: voltage supply +
2: -
3: voltage supply -
4: -

Some available Optics

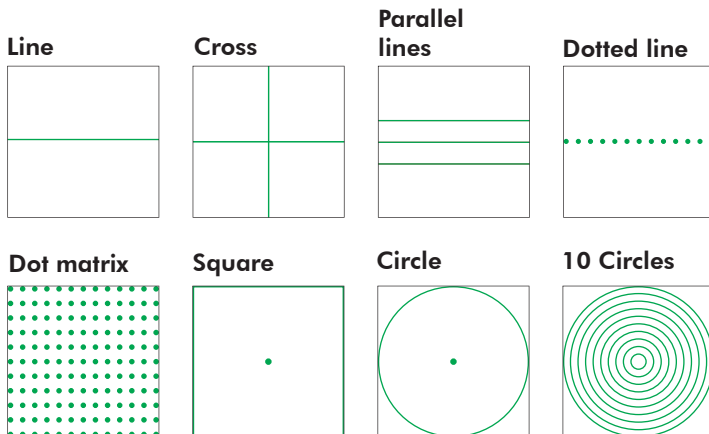

Mounting and power supply

H8-M18



WNG-9E-24



Specifications

Optical

Optical stability	< +/- 2% at constant temperature
Range of focus	100mm up to ∞
Divergence of beam	≤ 1mrad (with dot optic)
Direction failure of beam	+/- 10mrad
Pointing stability	< 50μrad / °C at constant temperature

Optics

Line (Gaussian profile)	60°, 90°, symmetrical or asymmetrical
Line (Non Gaussian profile)	10°, 20°, 30°, 45°, 60°, 90°
Point	elliptical or circular
DOE	see examples on front side

Wavelength and power

532nm	1-4mW
-------	-------

Electrical

Supply voltage	5-30VDC
Mode of operation	APC with current limiting or CC
Modulation	continuous wave
Protection	reverse polarity and transient/ESD
Connection	M12 plug, 4-pin

Mechanical

Dimensions	136mm x Ø 20mm
Housing	Laser: M18 industry housing, chromed brass Optic head: anodised aluminium
Protection category	IP 67
Weight	ca. 87g
Electrical isolation	potential free housing

Environmental conditions

Case temperature (with Z-LASER mounting)	0°C up to +35°C (with mounting H8-M18)
Storage temperature	-10°C up to +80°C
Humidity	Max. 90%, non condensing
MTTF at 25°C	> 10.000h

Order code:

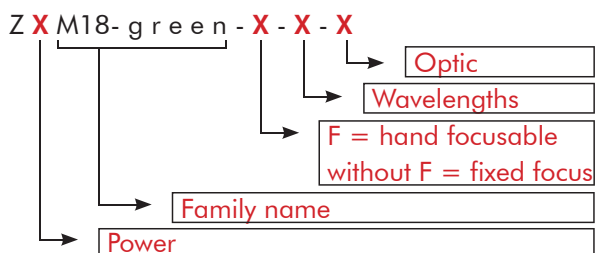

© **Z-LASER** / Subject to change

Z-LASER Optoelektronik GmbH • Merzhauser Str. 134 • 79100 Freiburg • Germany
Tel.: +49/761/296 44 44 • Fax: +49/761/296 44 55 • info@z-laser.de • www.z-laser.com