

# Mini-spectrometer TM series

## C10082MD, C10083MD

For UV to near IR, integrating optical system, image sensor and circuit



TM series mini-spectrometers are polychromators integrated with optical elements, an image sensor and a driver circuit. Two models are available: C10082MD (TM-UV/VIS-MOS) and C10083MD (TM-VIS/NIR-MOS). Light to be measured is guided into the entrance port of TM series through an optical fiber and the spectrum measured with the built-in image sensor is output from the USB port to a PC for data acquisition. No external power supply is required since USB bus power is used for circuit operation. The TM series comes with sample software, device driver and DLL. The sample software lets you easily set measurement conditions, acquire and save data, and display graphs.

### Features

- High throughput due to transmission grating made of quartz
- Highly accurate optical characteristics
- No external power supply required: Uses USB bus power
- Wide spectral response range
- Easy to install into equipment
- Wavelength conversion factor \*1 is recorded in internal memory
- Supports external trigger input \*2

### Applications

- Light source spectrum measurement
- Sunlight or illumination analysis
- Absorbance measurement

#### ■ Optical characteristics

Parameter	TM-UV/VIS-MOS	TM-VIS/NIR-MOS	Unit
	C10082MD	C10083MD	
Spectral response range	200 to 800	320 to 1000	nm
Spectral resolution Max. (Spectral response half width) *3	6	8	nm
Wavelength reproducibility *4	±0.2		nm
Wavelength temperature dependence	0.02		nm/°C
Spectral stray light *3, *5	-35	-33	dB

#### ■ Electrical characteristics

Parameter	Value	Unit
A/D conversion	16	bit
Integration time	5 to 10000	ms
Interface	USB1.1	-
USB bus power current consumption	100	mA

#### ■ General ratings / Absolute maximum ratings

Parameter	Value	Unit
Dimensions	94 (W) × 90 (D) × 55 (H)	mm
Image sensor	CMOS linear image sensor (S8378-1024Q)	-
Number of pixels	1024	pixels
Slit *6	70 (H) × 800 (V)	μm
Optical NA	0.22	-
Connector for optical fiber	SMA905D	-
Operating temperature *7	+5 to +40	°C
Storage temperature	-20 to +70	°C

\*1: A conversion factor for converting the image sensor pixel number into a wavelength is recorded in the module. A calculation factor for converting the A/D converted count into the input light intensity is not provided.

\*2: Coaxial cable for external trigger input sold separately. Refer to the "Mini-spectrometers Selection Guide" for details on external triggers.

\*3: Depends on the slit opening. Values were measured with the slit opening listed in the table.

\*4: Measured under constant light input conditions

\*5: When monochromatic light of the following wavelengths is input, spectral stray light is defined as the ratio of the count measured at the input wavelength, to the count measured in a region of the input wavelength ±40 nm.  
C10082MD: 500 nm, C10083MD: 650 nm

\*6: Entrance slit aperture size

\*7: No condensation

## Optical component layout

TM series mini-spectrometers use a transmission holographic grating made of quartz and precision optical components arranged on a rugged optical base, making it possible to deliver high throughput and highly accurate optical characteristics.

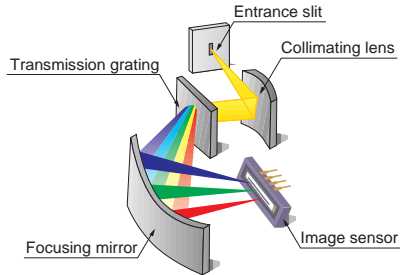

KACCC0287EA

## Connection example (transmission light measurement)

Light to be measured is guided into the entrance port of TM series through an optical fiber and the spectrum measured with the built-in image sensor is output through the USB port to a PC for data acquisition. There are no moving parts inside the unit so stable measurements are obtained at all times. An optical fiber that guides light input from external sources allows a flexible measurement setup.

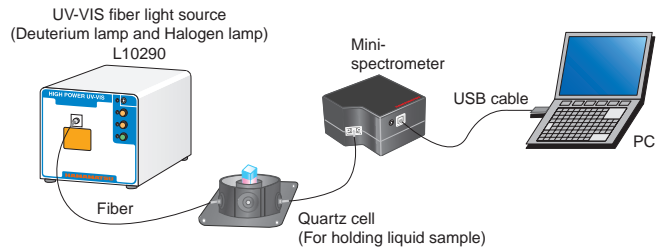

KACCC0288EF

## Dedicated software package (supplied with unit)

Installing the dedicated software package (containing sample software, device driver, DLL)\*<sup>8</sup> into your PC allows running the following basic tasks:

- Measurement data acquisition and save
- Measurement condition setup
- Module information acquisition (wavelength conversion factor, polychromator type, etc.)
- Graphic display
- Arithmetic operation
  - Pixel number to wavelength conversion
  - Dark subtraction
  - Comparison calculation with reference data (transmittance, reflectance)
  - Gaussian approximation (peak position and count, FWHM)

Note:

- Two or more mini-spectrometers can be connected and used with one PC simultaneously.
- The external trigger input function works with DLL, but does not function on the supplied sample software. If using an external trigger input, the user software must be configured to support that function.

\*8: Compatible OS: Microsoft Windows Professional Edition 2000 (SP3 or later) and XP (SP1a or later)

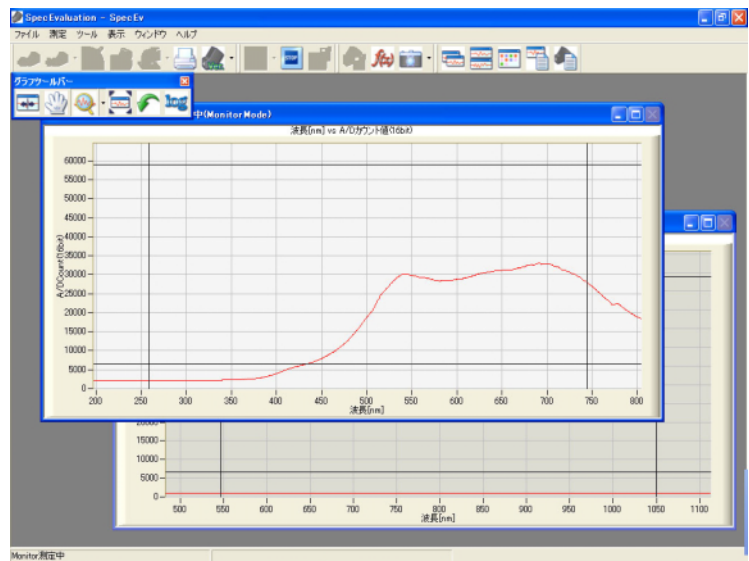

Device driver and DLL for controlling hardware are also provided.

You can develop your own measurement programs by using a software development environment that includes Microsoft Visual C++, Visual Basic and LabVIEW.\*<sup>9</sup> The DLL provides functions such as USB port open/close, measurement condition setup, measurement data and module information acquisition.

\*9: Operation of the device driver and DLL has been verified only with Microsoft Visual C++<sup>®</sup>, Visual Basic<sup>®</sup> and LabVIEW<sup>®</sup>.

Microsoft Visual C++ and Microsoft Visual Basic are either registered trademarks or trademarks of Microsoft Corporation in the United States and other countries. LabVIEW is registered trademark of National Instruments.

## ■ Measurement example

Line spectra from LED were measured with C10082MD (TM-UV/VIS-MOS)

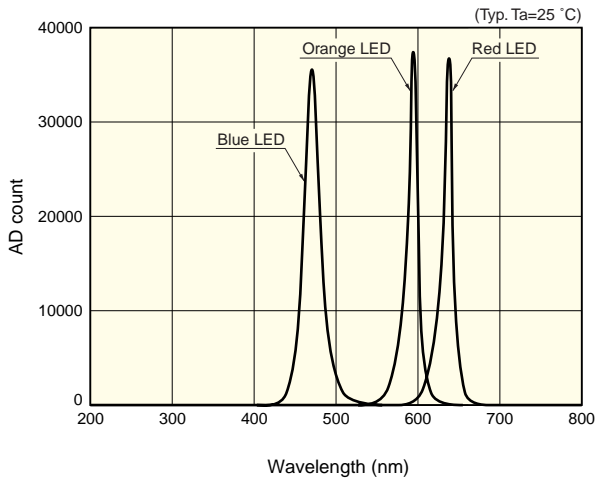

## ■ Dimensional outline

(unit: mm, tolerance unless otherwise noted: ±0.5)

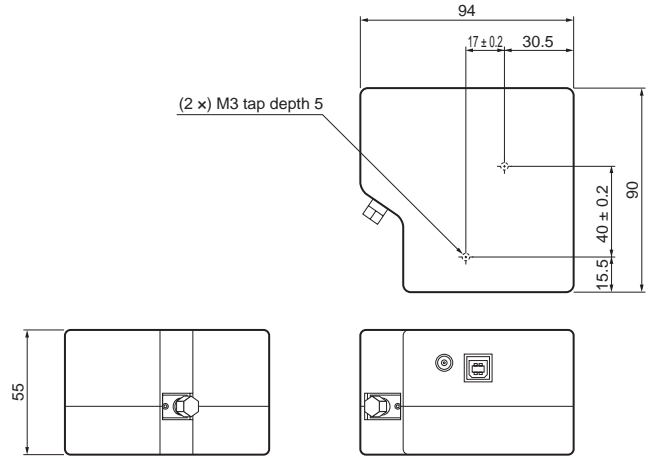

KACCB0126EA

KACCA0171ED

## ■ Accessories

- USB cable
- Dedicated software (sample software, device driver, DLL)

## ■ Options (sold separately)

- Coaxial cable for external trigger input A10670
- Optical fibers for light input

Type. No	Product name	Core diameter (μm)	Specification
A9762-01	Fiber for UV/visible range (resistance to UV)	600	N.A.=0.22, length 1.5 m, connectorized SMA905D at both ends



C10082MD, C10083MD conforms to the European EMC directives (Applied standard: EN 61326 Class B).

## ■ Mini-spectrometer line-up

Type No.	Type	Spectral response range (nm)											Spectral resolution Max. (nm)	Image sensor			
		200	400	600	800	1000	1200	1400	1600	1800	2000	2200					
C10082CA	TM-UV/VIS-CCD High sensitivity															6	Back-thinned type CCD image sensor
C10082CAH	TM-UV/VIS-CCD High resolution		200 to 800													1*	
C10082MD	TM-UV/VIS-MOS Wide dynamic range															6	
C10083CA	TM-VIS/NIR-CCD High sensitivity															8 (λ=320 to 900 nm)	Back-thinned type CCD image sensor
C10083CAH	TM-VIS/NIR-CCD High resolution			320 to 1000												1* (λ=320 to 900 nm)	
C10083MD	TM-VIS/NIR-MOS Wide dynamic range															8	
C9404CA	TG-UV-CCD High sensitivity															3	Back-thinned type CCD image sensor
C9404CAH	TG-UV-CCD High resolution		200 to 400													1*	
C9404MC	TG-UV-MOS Wide dynamic range															3	
C9405CA	TG-SWNIR-CCD High sensitivity															5 (λ=550 to 900 nm)	Back-thinned type CCD image sensor
C9405MC	TG-SWNIR-MOS Wide dynamic range				500 to 1100											5 (λ=550 to 1100 nm)	
C9406GC	TG-NIR Non-cooled type															7	InGaAs linear image sensor
C9913GC	TG-cooled NIR-I Low noise (cooled type)															7	
C9914GB	TG-cooled NIR-II Low noise (cooled type)															8	
C9407MA	RC-VIS-MOS Spectrometer module															9	CMOS linear image sensor
C9408MA	RC-SWNIR-MOS Spectrometer module															8	

\* Typ.

### OEM model

Type No.	Type	Spectral response range (nm)											Spectral resolution Max. (nm)	Image sensor			
		200	400	600	800	1000	1200	1400	1600	1800	2000	2200					
C9409MA	RC-VIS-MOS Spectrometer head															9	CMOS linear image sensor
C9410MA	RC-SWNIR-MOS Spectrometer head															8	