

Mini-spectrometer TG series C9406GC, C9913GC, C9914GB

For near IR, integrating optical system, image sensor and circuit



Hamamatsu TG series mini-spectrometers are polychromators integrated with optical elements and an image sensor. Light to be measured is guided into the entrance port of TG series through an optical fiber and the spectrum measured with the built-in image sensor is output from the USB port to a PC for data acquisition. Non-cooled type and cooled type are provided. Non-cooled type is a palmtop-size unit and operates on USB bus power. Cooled type allows accurate measurement with low noise by cooling the image sensor. Two models are available: C9913GC (TG-cooled NIR-I) and C9914GB (TG-cooled NIR-II). The TG series comes with sample software, device driver and DLL that let you easily set measurement conditions and acquire, save and graphically display the spectrum data.

Features

- High throughput due to transmission grating made of quartz
- Highly accurate optical characteristics
- G9406GC: No external power supply required (Uses USB bus power) *1
- Low noise measurement (Cooled type: C9913GC, C9914GB)
- Compact design for easy assembly
- Wavelength conversion factor *2 is recorded in internal memory

Applications

- C9406GC (TG-NIR)
- Water content measurement
 - Optical communication component testing
 - Film thickness measurement
- C9913GC (TG-cooled NIR-I), C9914GB (TG-cooled NIR-II)
- Water content measurement
 - Component analysis in food, agriculture fields, etc.
 - Process control for chemical products

*1: C9913GC, C9914GB: Each requires 5 V and 12 V power supplies.

*2: A conversion factor for converting the image sensor pixel number into a wavelength is recorded in the module. A calculation factor for converting the A/D converted count into the input light intensity is not provided.

Mini-spectrometer line-up

Type No.	Type	Spectral response range (nm)											Spectral resolution Max. (nm)	Image sensor						
		200	400	600	800	1000	1200	1400	1600	1800	2000	2200								
C10082CA	TM series	TM-UV/VIS-CCD [High sensitivity]															6	Back-thinned type CCD image sensor		
C10082CAH		TM-UV/VIS-CCD [High resolution]		200 to 800															1*	
C10082MD		TM-UV/VIS-MOS [Wide dynamic range]																6	CMOS linear image sensor	
C10083CA		TM-VIS/NIR-CCD [High sensitivity]																8 (λ=320 to 900 nm)	Back-thinned type CCD image sensor	
C10083CAH		TM-VIS/NIR-CCD [High resolution]			320 to 1000													1* (λ=320 to 900 nm)		
C10083MD		TM-VIS/NIR-MOS [Wide dynamic range]																8	CMOS linear image sensor	
C9404CA	TG series	TG-UV-CCD [High sensitivity]																3	Back-thinned type CCD image sensor	
C9404CAH		TG-UV-CCD [High resolution]	200 to 400															1*		
C9404MC		TG-UV-MOS [Wide dynamic range]																	3	CMOS linear image sensor
C9405CA		TG-SWNIR-CCD [High sensitivity]																	5 (λ=550 to 900 nm)	Back-thinned type CCD image sensor
C9405MC	TG-SWNIR-MOS [Wide dynamic range]																	5 (λ=550 to 1100 nm)		
C9406GC	TG series	TG-NIR [Non-cooled type]																7	InGaAs linear image sensor	
C9913GC		TG-cooled NIR-I [Low noise (cooled type)]																7		
C9914GB		TG-cooled NIR-II [Low noise (cooled type)]																8		
C9407MA	RC series	RC-VIS-MOS [Spectrometer module]																9	CMOS linear image sensor	
C9408MA		RC-SWNIR-MOS [Spectrometer module]																8		

* Typ.

OEM model

Type No.	Type	Spectral response range (nm)											Spectral resolution Max. (nm)	Image sensor					
		200	400	600	800	1000	1200	1400	1600	1800	2000	2200							
C9409MA	RC series	RC-VIS-MOS [Spectrometer head]																9	CMOS linear image sensor
C9410MA		RC-SWNIR-MOS [Spectrometer head]																8	

Specifications

Non-cooled type

Parameter	TG-NIR	Unit
	C9406GC	
Number of pixels	512	pixels
Spectral response range	900 to 1700	nm
Spectral resolution Max. (Spectral response half width) *3	7	nm
Wavelength reproducibility *4	±0.2	nm
Wavelength temperature dependence	0.02	nm/°C
Spectral stray light *3, *5	-35	dB
Broadband stray light *3, *6	-30	dB
Slit *7	70 (H) × 500 (V)	μm
A/D conversion	16	bit
Integration time	5 to 10000	ms
Optical N.A. *8	0.22	-
Image sensor	InGaAs linear image sensor (G9204-512D)	-
Connector for optical fiber	SMA905D	-
Interface	USB1.1	-
Current consumption *9	250	mA
Operating temperature *10	+5 to +40	°C
Storage temperature	-20 to +70	°C
Dimensions	40 (W) × 106 (D) × 86 (H)	mm

Cooled type

Parameter	TG-cooled NIR-I	TG-cooled NIR-II	Unit
	C9913GC	C9914GB	
Number of pixels	512	256	pixels
Spectral response range	900 to 1700	1100 to 2200	nm
Spectral resolution *3 (Spectral response half width)	7	8	nm
Wavelength reproducibility *4	±0.2	±0.4	nm
Wavelength temperature dependence	0.02	0.04	nm/°C
Spectral stray light *3, *5	-35	-35	dB
Broadband stray light *3, *6	-30	-30	dB
Slit *7	70 (H) × 500 (V)	70 (H) × 250 (V)	μm
A/D conversion	16		bit
Integration time	5 to 10000	5 to 1000	ms
Optical N.A. *8	0.22	0.22	-
Image sensor	InGaAs linear image sensor (G9204-512S)	InGaAs linear image sensor (G9206-02)	-
Image sensor cooling temperature	-5	-20	°C
Connector for optical fiber	SMA905D		-
Interface	USB1.1		-
USB bus power current consumption	250	250	mA
Power supply for cooling element (Max.) *11	5/1.8	5/2.8	V/A
Power supply for cooling fan *11	12/0.2		V/A
Operating temperature *10	+5 to +35 (+5 to +30 *12)		°C
Storage temperature	-20 to +70		°C
Dimensions	142 (W) × 218 (D) × 80 (H)		mm

*3: Depends on the slit opening. Values were measured with the slit opening listed in the table.

*4: Measured under constant light input conditions.

*5: When monochromatic light of the following wavelengths is input, spectral stray light is defined as the ratio of the count measured at the input wavelength, to the count measured in a region of the input wavelength ±40 nm.
C9406GC/C9913GC: 1300 nm, C9914GB: 1650 nm

*6: This is the ratio of the transmittance measured with light passing through the following optical filters to the transmittance measured in the blocking region.

C9406GC/G9913GC: LP1400 (SPECTROGON), C9914GB: LP1700 (SPECTROGON)

*7: Entrance slit aperture size

*8: Numerical aperture (solid angle)

*9: USB bus power

*10: No condensation

*11: Maximum value in steady state. Note that inrush current flows at start-up.

*12: For controllable cooling temperature

Optical component layout

TG series mini-spectrometers use a transmission holographic grating made of quartz and precision optical components arranged on a rugged optical base, making it possible to deliver high throughput and highly accurate optical characteristics.

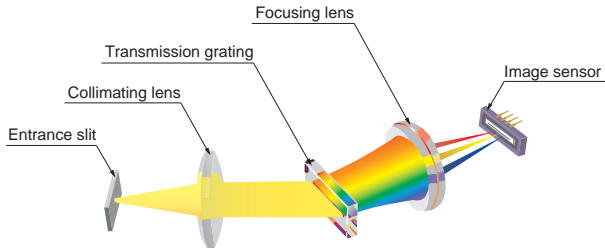

KACC00256EA

Connection example (transmission light measurement)

Light to be measured is guided into the entrance port of TG series through an optical fiber and the spectrum measured with the built-in image sensor is output through the USB port to a PC for data acquisition. There are no moving parts inside the unit so stable measurements are obtained at all times. An optical fiber that guides light input from external sources allows a flexible measurement setup.

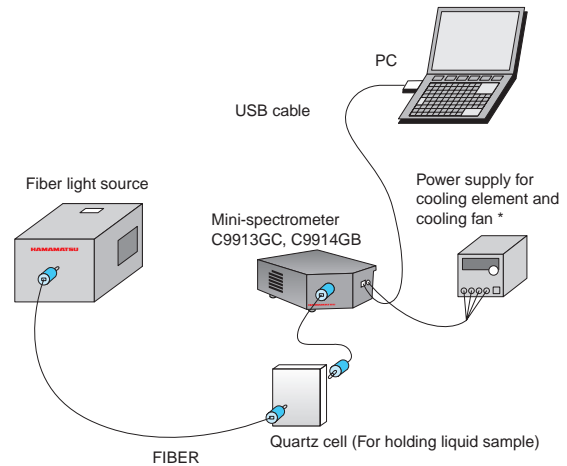

* External power supply should be prepared by the user.
C9406GC: No external power supply required (Uses USB bus power)

KACC00370EB

Dedicated software package (supplied with unit)

Installing the dedicated software package (containing sample software, device driver, DLL)*13 into your PC allows running the following basic tasks:

- Measurement data acquisition and save
- Measurement condition setup
- Module information acquisition (wavelength conversion factor, polychromator type, etc.)
- Graphic display
- Arithmetic operation
 - Pixel number to wavelength conversion
 - Dark subtraction
 - Comparison calculation with reference data (transmittance, reflectance)
 - Gaussian approximation (peak position and count, FWHM)

Note: Two or more mini-spectrometers can be connected and used with one PC simultaneously.

*13: Compatible OS: Microsoft Windows Professional Edition 2000 (SP3 or later) and XP (SP1a or later)

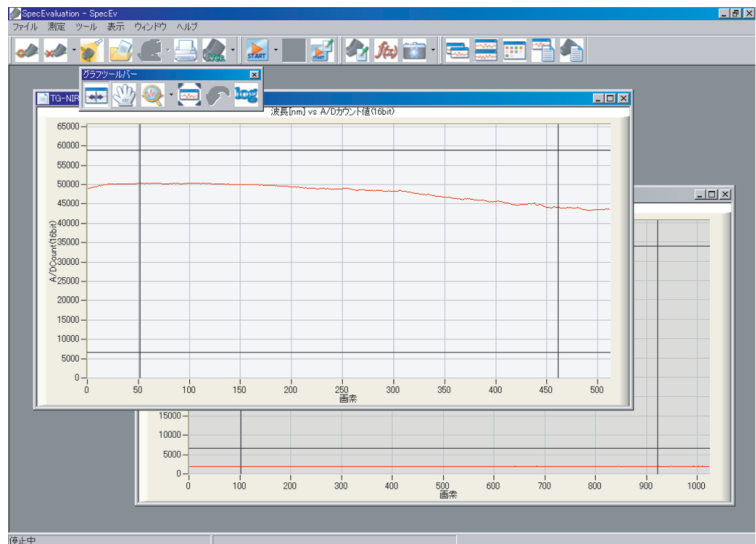

Device driver and DLL for controlling hardware are also provided.

You can develop your own measurement programs by using a software development environment that includes Microsoft Visual C++, Visual Basic and LabVIEW.*14 The DLL provides functions such as USB port open/close, measurement condition setup, measurement data and module information acquisition.

*14: Operation of the device driver and DLL has been verified only with Microsoft Visual C++®, Visual Basic® and LabVIEW®. Microsoft Visual C++ and Microsoft Visual Basic are either registered trademarks or trademarks of Microsoft Corporation in the United States. LabVIEW is registered trademark of National Instruments.

■ Measurement example

- Film thickness measurement (white light interferometry)
- Thickness of 10 μm thick food wrapping film (polyvinylidene chloride) was measured with C9406GC (TG-NIR).

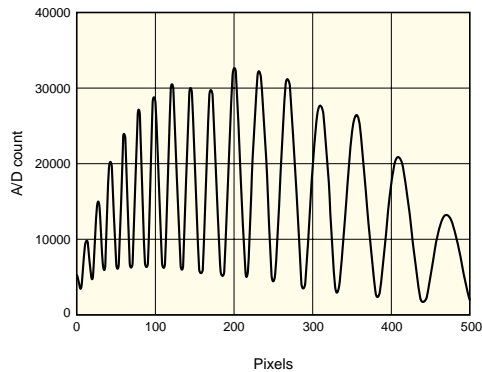

KACCB0095EA

Note:

Principle of film thickness measurement:

In film thickness measurement utilizing white light interferometry, an interference spectrum resulting from internal reflections between the front and back surfaces of a film is obtained.

The film thickness can then be determined by calculation from the spectral peak count, wavelength range, refractive index of film and incident light angle.

■ Dimensional outline (unit: mm, tolerance unless otherwise noted: ±0.5)

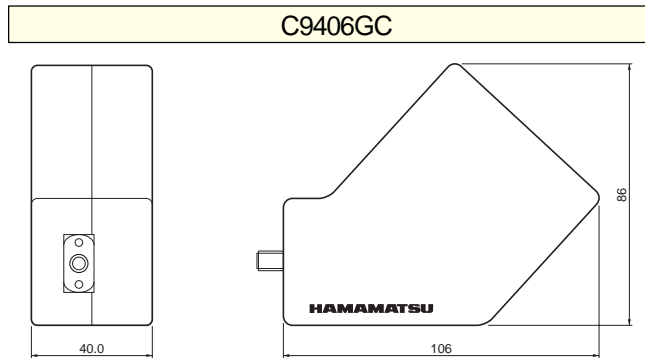

KACCA0146EA

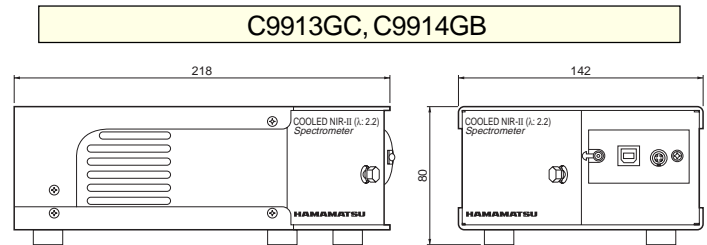

KACCA0158EB

■ Accessories

- USB cable
- Dedicated software (sample software, device driver, DLL)
- Connector for connection to cooling element and cooling fan power supply (C9913GC, C9914GB)

■ Options (sold separately)

Optical fibers for light input

Type. No	Product name	Specification
A9763-01	Fiber for visible/ near infrared range	Core diameter 600 μm, N.A.=0.22, length 1.5 m, connectorized SMA905D at both ends



C9406GC, C9913GC, C9914GB conforms to the European EMC directives (Applied standard: EN 61326-1 Class B).

HAMAMATSU

Information furnished by HAMAMATSU is believed to be reliable. However, no responsibility is assumed for possible inaccuracies or omissions. Specifications are subject to change without notice. No patent rights are granted to any of the circuits described herein. ©2009 Hamamatsu Photonics K.K.

HAMAMATSU PHOTONICS K.K., Solid State Division

1126-1 Ichino-cho, Higashi-ku, Hamamatsu City, 435-8558 Japan, Telephone: (81) 53-434-3311, Fax: (81) 53-434-5184, www.hamamatsu.com

U.S.A.: Hamamatsu Corporation: 360 Foothill Road, P.O.Box 6910, Bridgewater, N.J. 08807-0910, U.S.A., Telephone: (1) 908-231-0960, Fax: (1) 908-231-1218

Germany: Hamamatsu Photonics Deutschland GmbH: Arzbergerstr. 10, D-82211 Herrsching am Ammersee, Germany, Telephone: (49) 08152-3750, Fax: (49) 08152-2658

France: Hamamatsu Photonics France S.A.R.L.: 19, Rue du Saule Trapu, Parc du Moulin de Massy, 91882 Massy Cedex, France, Telephone: 33-(1) 69 53 71 00, Fax: 33-(1) 69 53 71 10

United Kingdom: Hamamatsu Photonics UK Limited: 2 Howard Court, 10 Tewin Road, Welwyn Garden City, Hertfordshire AL7 1BW, United Kingdom, Telephone: (44) 1707-294888, Fax: (44) 1707-325777

North Europe: Hamamatsu Photonics Norden AB: Smidesvägen 12, SE-171 41 Solna, Sweden, Telephone: (46) 8-509-031-00, Fax: (46) 8-509-031-01

Italy: Hamamatsu Photonics Italia S.R.L.: Strada della Moia, 1/E, 20020 Arese, (Milano), Italy, Telephone: (39) 02-935-81-733, Fax: (39) 02-935-81-741

Cat. No. KACC1141E04
Apr. 2009 DN