

AG32S



Features

- UVB & UVC selective photodiode
- Optimally suited for sun-UV dosimetry
- Intrinsically insensitive in the UVA and in the visible due to the wide-bandgap semiconductor material AlGaN
- TO-18 metal package with 0,076 mm² active chip area
- High speed and low noise

Maximum Ratings

Parameter	Symbol	Value	Unit
Operating temperature range	T _{opt}	-25 ... +80	°C
Reverse voltage	V _{Rmax}	5	V



AG32S

General Characteristics

($T_a = 25\text{ °C}$)

Parameter	Symbol	Value	Unit
Active area	A	0.076	mm ²
Dark current at 0.1 V reverse bias	I_d	100	fA
Capacitance	C	24	pF
Short circuit current at bright sun	I_0	ca. 6	nA

Spectral Characteristics

($T_a = 25\text{ °C}$)

Parameter	Symbol	Value	Unit
Max. spectral sensitivity	S_{max}	0.1	A W ⁻¹
Wavelength of max. spectral sensitivity	λ_{Smax}	300	nm
Range of spectral sensitivity ($S=0.1*S_{max}$)	-	225 - 317	nm

Linear Spectral Response

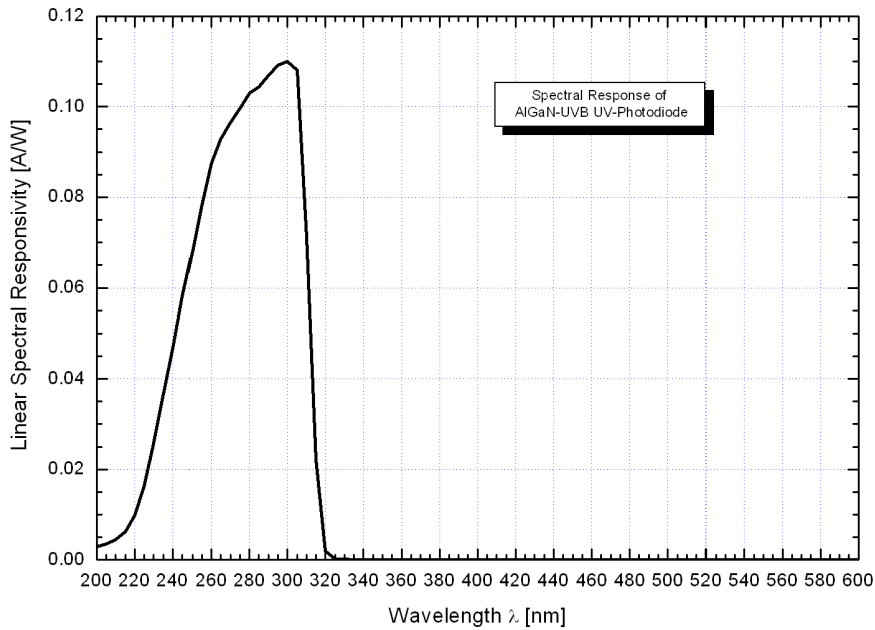

Logarithmic Spectral Response

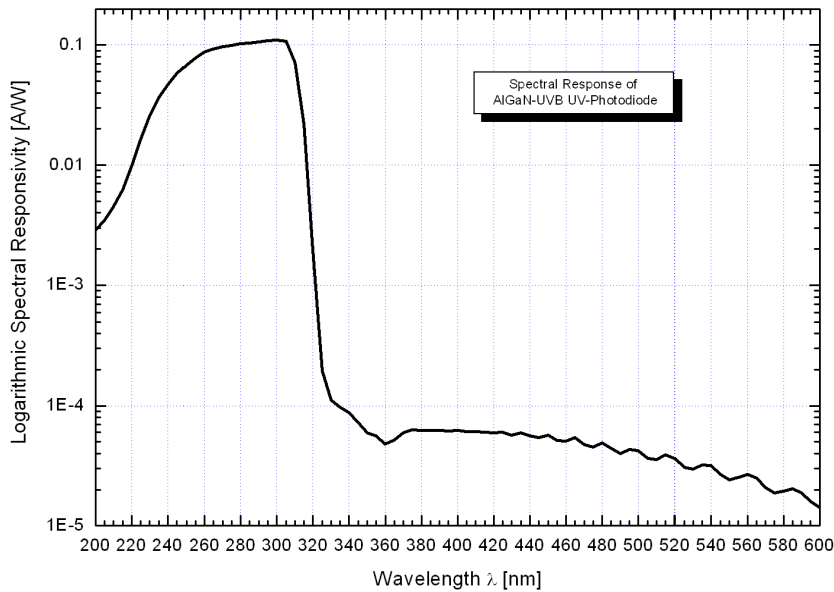

Application Example

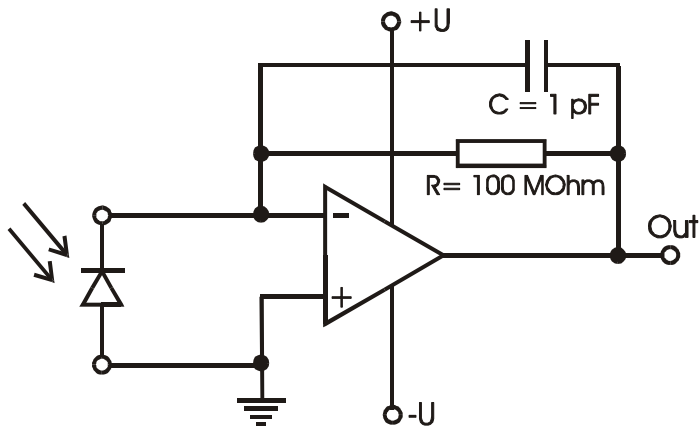

Pin Layout

