

SG01S-HT

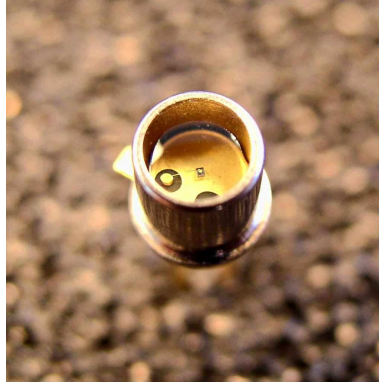

Features

- Operating Temperature up to 170°C
- Broad Band UVA-UVB-UVC Photodiode
- Optimally suited for UVC high radiation control
- Silicon Carbide based chip for extreme irradiation hardness
- Intrinsic visible blindness due to wide-bandgap semiconductor material
- TO-18 metal package with 0.054 mm² active chip area
- The chip is manufactured by Cree Research Inc., U.S.A.

Maximum Ratings

Parameter	Symbol	Value	Unit
Operating temperature range	T _{opt}	-25 ... +70	°C
Reverse voltage	V _{Rmax}	20	V



SG01S-HT

General Characteristics ($T_a = 25\text{ }^\circ\text{C}$)

Parameter	Symbol	Value	Unit
Active area	A	0.054	mm ²
Dark current at 1 V reverse bias	I_d	1	fA
Capacitance	C	21	pF
Short circuit current at bright sun	I_0	ca. 70	nA

Spectral Characteristics ($T_a = 25\text{ }^\circ\text{C}$)

Parameter	Symbol	Value	Unit
Max. spectral sensitivity	S_{max}	0,13	A W ⁻¹
Wavelength of max. spectral sensitivity	λ_{Smax}	285	nm
Range of spectral sensitivity ($S=0.1*S_{max}$)	-	210 - 380	nm



SG01S-HT

Linear Spectral Response

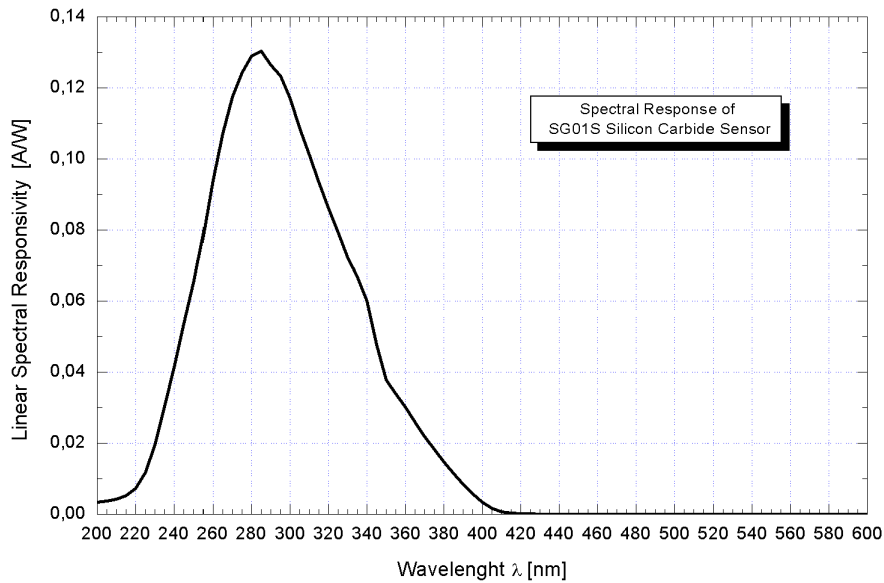

Logarithmic Spectral Response

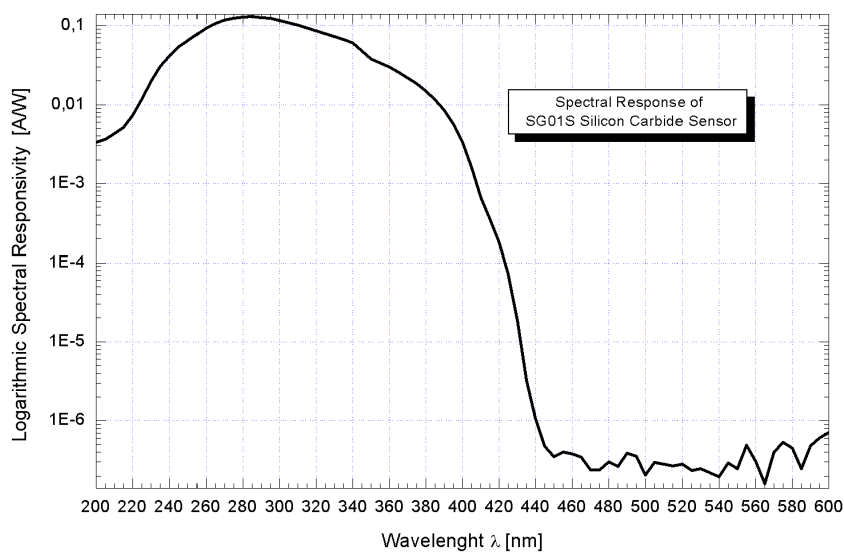

Ultraviolet selective SiC based UV sensor



SG01S-HT

Application Example

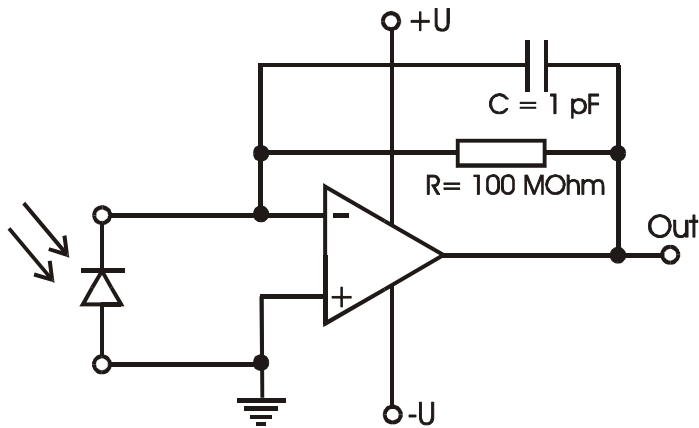

Pin Layout

