

Ultraviolet selective thin film sensor TW30DZ



NEW: Read important application notes on page 4 ff.



Features

- Schottky-type photodiode
- Intrinsic visible blindness due to wide-bandgap semiconductor material
- Built-in filter glass for low sensitivity above 400nm
- Large photoactive area
- No focusing lens needed, therefore large usable incident angle
- Designed to operate in photovoltaic mode
- TO-46 metal package

Maximum Ratings

Parameter	Symbol	Value	Unit
Operating temperature range	T_{opt}	-20 ... +80	°C
Reverse voltage	V_{Rmax}	3	V
Forward current	I_{Fmax}	1	mA
Total power dissipation at 25°C	P_{tot}	1	mW

Ultraviolet selective thin film sensor TW30DZ



NEW: Read important application notes on page 4 ff.

General Characteristics

($T_a = 25\text{ °C}$)

Parameter	Symbol	Value	Unit
Active area	A	4,18	mm ²
Active area dimensions	L x W	2.2 x 1.9	mm ²
Max. viewing angle	α	app. 70	degree
Shunt resistance (dark)	R_s	300	M Ω
Dark current at 10mV reverse bias	I_d	30	pA
Open circuit voltage (200 μ W/cm ² , $\lambda=300$ nm)	V_0	>250	mV
Short circuit current (200 μ W/cm ² , $\lambda=300$ nm)	I_0	167	nA
Breakdown voltage (dark)	V_{BR}	> 3	V

Spectral Characteristics

($T_a = 25\text{ °C}$)

Parameter	Symbol	typ. Value	Unit
Max. spectral sensitivity	S_{max}	20	mA W ⁻¹
Wavelength of max. spectral sensitivity	λ_{Smax}	300	nm
Range of spectral sensitivity ($S=0.1*S_{max}$)	-	253-361	nm
Visible blindness	$\frac{S_{max}}{S_{400nm}}$	>1.000	

Ultraviolet selective thin film sensor TW30DZ



NEW: Read important application notes on page 4 ff.

Spectral Response

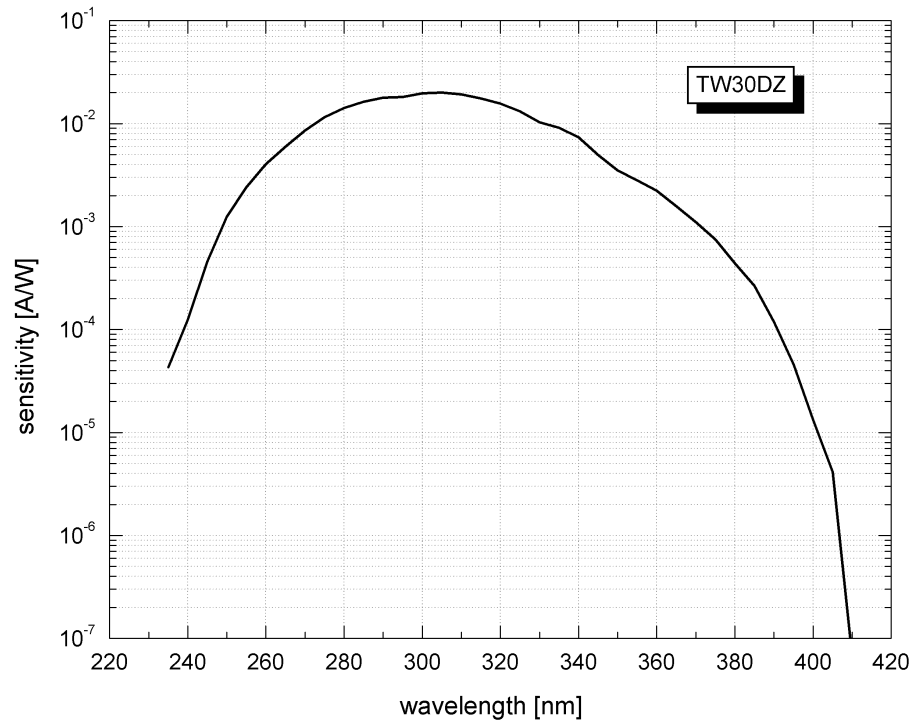

Pin Layout

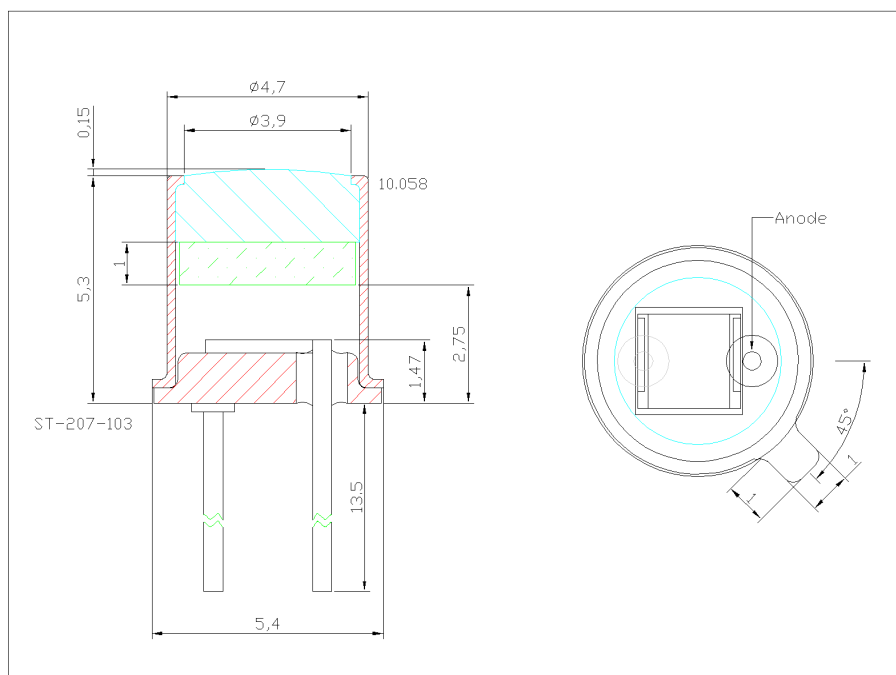

NEW: Read important application notes on page 4 ff.

Application notes

Our polycrystalline UV photodiodes are designed for **photovoltaic operation**. This operation mode is necessary to minimize the dark current of large area photo detectors which otherwise needs to be considered in the commonly used photoconductive mode.

First we want to show the implementation of photovoltaic operation with **commercially available** photodiode (current) **amplifiers**.

Many amplifier devices provide an adjustable bias voltage. This has to be switched off or trimmed to well below 0.1 V in order to ensure photovoltaic operation. In this case the connection of our photodiodes to such devices is rather simple, see figure 1.

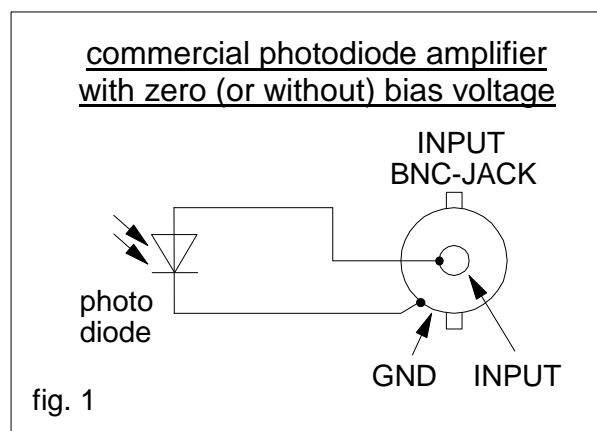

Some amplifiers only have a fixed bias voltage or the bias cannot be trimmed to near zero. In this case it is required to draw the ground level (which is not available on the input jack) from other sources, e.g. the output jack, special connectors or even from the housing. Please refer to the amplifier's manual and figure 2.

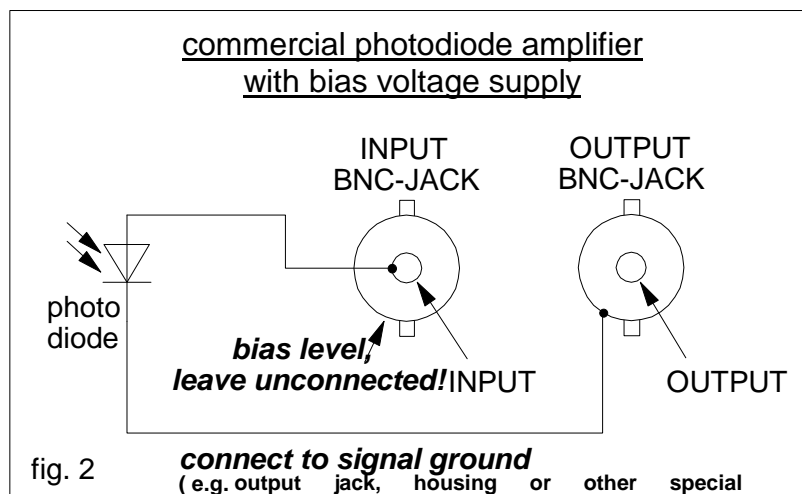

Design of custom photodiode amplifiers

This complex topic strongly depends on your specific application. We provide flexible “ready to use” amplifier boards, consultation, development support as well as engineering solutions.

Nevertheless, we offer some examples, references for further reading and keywords for your convenience.

- Use amplifier chips with low input offset voltages and currents. Examples:
high end: OPA128 (Texas instruments, Burr Brown)
medium: TLV277x, TLC227x (Texas Instruments)
low end: TL07x, TL08x (Texas instruments)
- Use transimpedance setup with feedback resistors not above 10 M Ω and without bias voltage. The figure below shows the basic schematic, however, all textbooks on basics of electronics cover plenty of details.
Please also refer to the application note “*DESIGNING PHOTODIODE AMPLIFIER CIRCUITS WITH OPA128*”, (Texas Instruments, Burr Brown).
If amplification above 10⁷ V/A is required two stage amplifiers perform better.

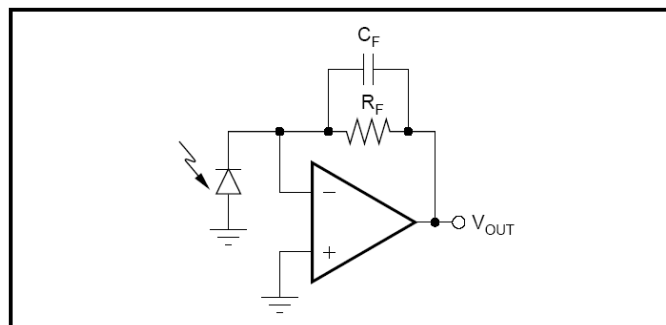

- For stability reasons apply a feedback capacitor parallel C_F to the feedback resistor R_F . Value depends on various parameters.
Please also refer to the application note “*COMPENSATE TRANSIMPEDANCE AMPLIFIERS INTUITIVELY*”, (Texas Instruments, Burr Brown).
- Hint: Use 10 nF with OPA128 and 2 nF with TL07x, higher values minimize the noise dependence but also the bandwidth.
- Always use proper shielding, even on PCB: guard layers and wires are strongly recommended; reduce distances between sensor and amplifier chip; prevent ground loops. For general understanding of operational amplifier properties refer to the white paper (SLOA011) “*Understanding Operational Amplifier Specifications*” from Texas Instruments.

For further information, please feel free to contact us. All references can be found on the Texas Instruments website www.ti.com. Given products and information are to be considered as examples only. No guarantee is given for completeness or correctness. We take no responsibility for damages caused by using this information.