

The SG01L4-5 is a SiC photodiode array based on four 1mm² SiC detector chips. The sensor is used for low noise ultra low UV radiation measurements such as Meteorological, Flight and Space applications.

Features

- Broad band UVA-UVB-UVC photodiode in TO5 metal package
- Silicon Carbide based chip for extreme low noise
- Chip dimensions of 4 x 1 x 1 mm² with 3.84 mm² active area
- Completely insensitive to the visible ($S_{280\text{nm}} / S_{400\text{nm}} > 10^4$)
- Designed for meteorological and space applications
- Please consider 30µm blind lines between the chips

Maximum Ratings

Parameter	Symbol	Value	Unit
Operating temperature range	T _{opt}	-25...+70	°C
Reverse voltage	V _{Rmax}	20	V

Technical Data (T_a=25°C)

Parameter	Symbol	Value	Unit
Active Area	A	4x0,96 = 3,84	mm ²
Dark Current at 1V reverse bias	I _d	2	fA
Capacitance	C	800	pF
Short circuit current at bright sun	I	ca. 3,200	nA
Max. spectral sensitivity	S _{max}	0.13	AW ⁻¹
Wavelength of max. spectral sensitivity	λ _{Smax}	280	nm
Range of spectral sensitivity (S=0.1*S _{max})	-	220-360	nm



Spectral Response

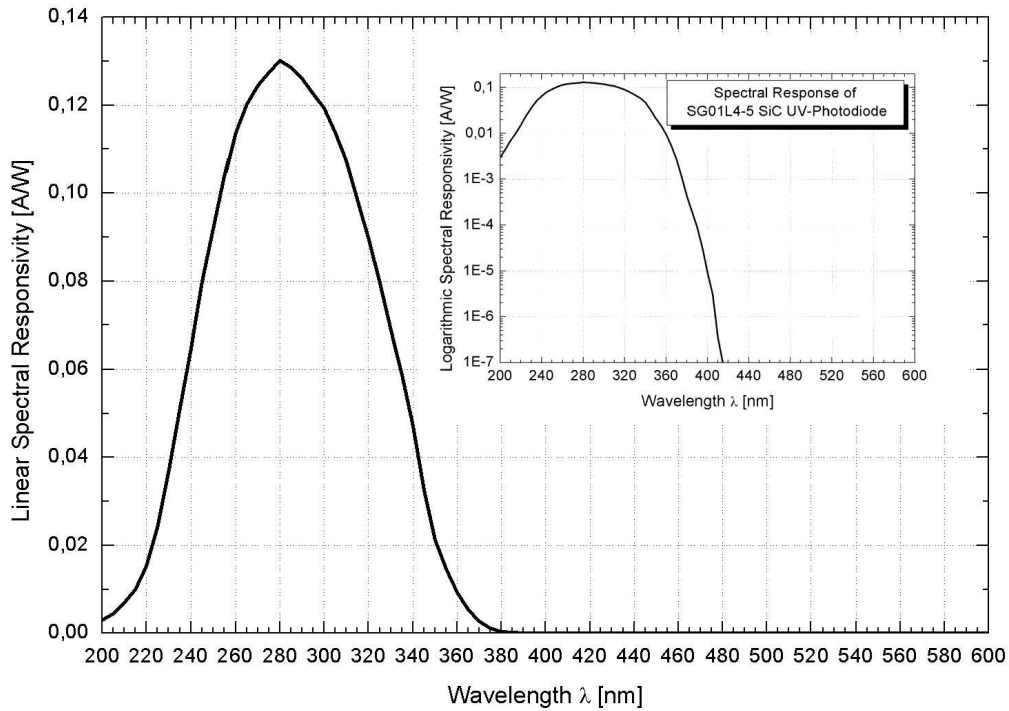

Application Example

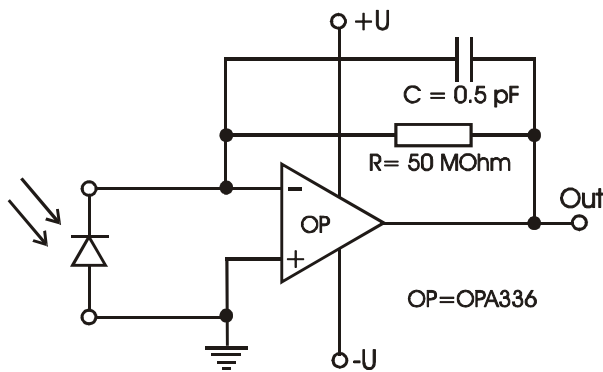

- please use transimpedance current-to-voltage amplifiers
- do not use voltage-to-voltage amplifier circuits

Pin Layout

