

The SG01L4-5 is a SiC photodiode array based on four 1mm² SiC detector chips. The sensor is used for low noise ultra low UVC only radiation measurements such as Meteorological, Flight and Space applications.

Features

- UVC sensitive photodiode in TO5 metal package
- Silicon Carbide based chip for extreme low noise
- Chip dimensions of 4 x 1 x 1 mm² with 3,84 mm² active area
- Completely insensitive from 295nm ($S_{270\text{nm}} / S_{>295\text{nm}} > 10^4$)
- Designed for meteorological and space applications
- Please consider 30µm blind lines between the chips

Maximum Ratings

Parameter	Symbol	Value	Unit
Operating temperature range	T_{opt}	-25...+70	°C
Reverse voltage	V_{Rmax}	20	V

Technical Data ($T_a=25^\circ\text{C}$)

Parameter	Symbol	Value	Unit
Active Area	A	4x0,96 = 3.84	mm ²
Dark Current at 1V reverse bias	I_d	2	fA
Capacitance	C	800	pF
Max. spectral sensitivity	S_{max}	0.11	AW ⁻¹
Wavelength of max. spectral sensitivity	$\lambda_{S\text{max}}$	270	nm
Range of spectral sensitivity ($S=0.1 \cdot S_{\text{max}}$)	-	227-285	nm

Spectral Response

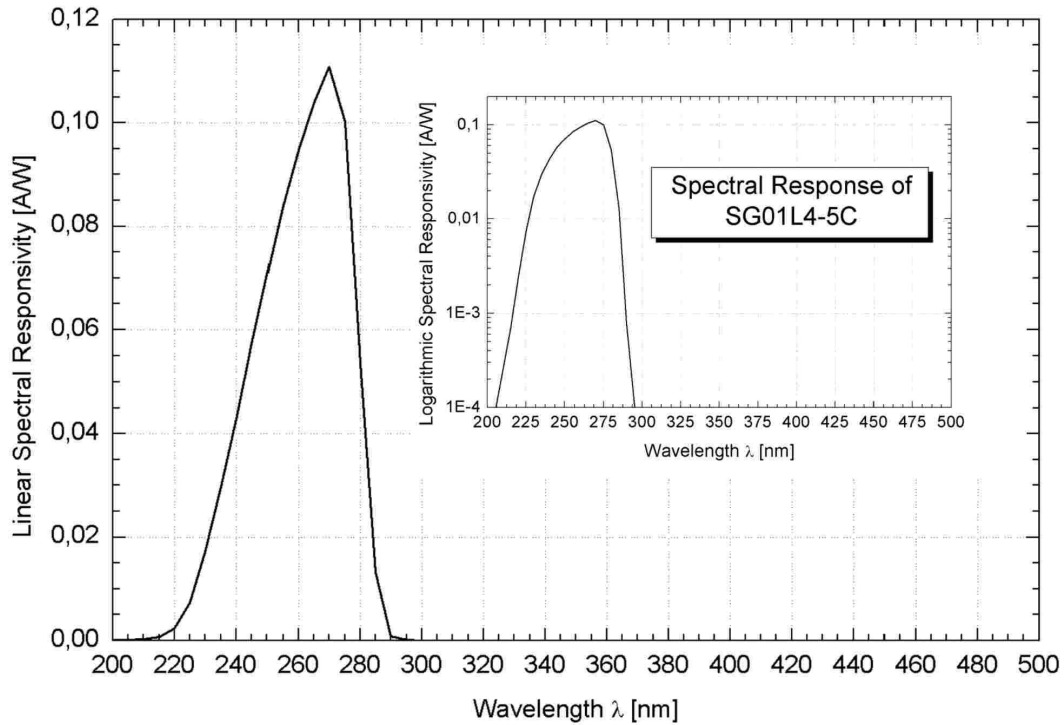

Application Example

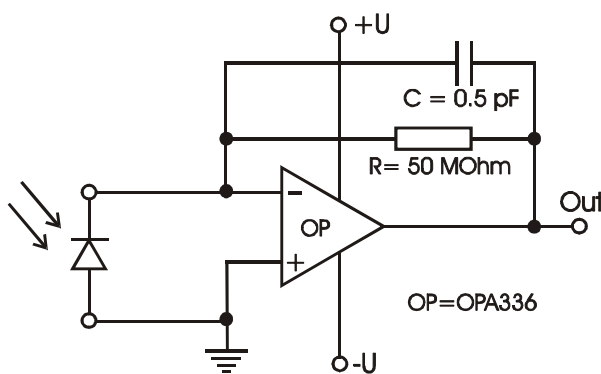

- please use transimpedance current-to-voltage amplifiers
- do not use voltage-to-voltage amplifier circuits

Pin Layout

